

# Ariete NS3075



**From the world leader in high pressure homogenization: absolute quality and reliability with advanced technical solutions for any process need.**

#### LIQUID END

- High quality stainless steel and special high wear resistance materials for best mechanical and corrosion resistance performances
- 3A and electropolished versions available
- Ball (PVB) and poppet valves (PVP) interchangeable into the same block design for maximum product handling flexibility
- Aseptic version compression block available with sterile condensate packing flushing
- Various materials for pumping plungers

#### HOMOGENIZING VALVE

- One stage (standard on homogenizers) with pneumatic adjustment from the machine's control panel
- High efficiency design valve NanoVALVE™, based on advanced fluid dynamics concepts, available as option
- Engineered for easy maintenance and cleaning
- Second stage option

#### POWER END

- Heavy duty and reliable power frame
- AC motor drive
- Forced lubrication with gear pump and low oil pressure switch
- "V" belts drive train and gearbox speed reduction unit

#### CASING

- Made in polished stainless steel with sound proof lining
- Easy access and maintenance with removable panels
- Noise reduction execution ( $\leq 75\text{dB}$ ) available

#### TOOLS AND SPARE PARTS

- Special tools and one set of emergency spare parts supplied with the machine
- O&M manual and spare part list on CD-ROM

**GEA Niro Soavi**  
Leading Pressure

# Ariete NS3075

- Designed according to the EU safety rules (CE standards), engineered, manufactured and tested according to ISO EN 9001 Quality System
- Sanitary and aseptic execution, designed for CIP and SIP
- Suitable for abrasive and viscous products
- Homogenizing pressure up to 1500 bar
- Monoblock compression head design up to 600 bar pressure
- Multiblock VHP compression head design for operation over 600 bar, to avoid stress concentration and block failure
- Easy implementation in remote controlled systems and complete process lines

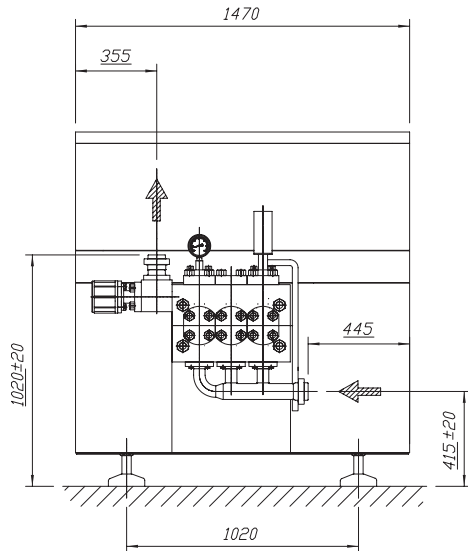

measure in mm

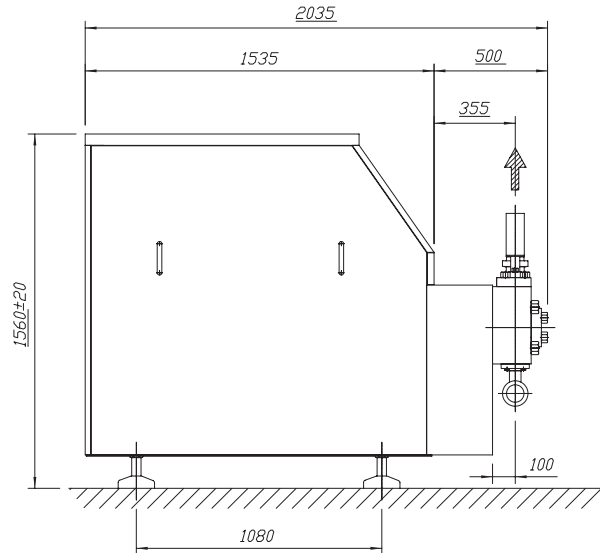

Technical specifications are not mandatory and subject to change without notice

## PERFORMANCES

Pressure (bar)	Max Flow Rate (l/h)
100	14000
150	14000
200	11000
250	8200
400	4900
600	3100
1000	1400
1200	1400
1500	1000

## TECHNICAL DATA

Number of plungers	3
Stroke	80 mm
Absorbed motor power up to	75 kW
Weight	2400 kg
Water consumption	90 l/h
Lubricating oil ISO VG 150	30 l
Gearbox oil EP 220 (NS3075)	18 l
(NS3075/45)	13 l

## COMPRESSION HEAD

- Special high grade duplex / super-duplex SS alloy
- Monoblock or Multiblock VHP construction

## PUMP VALVES

- High wear resistant Stellite™ alloy removable seats
- Ball type (PVB) or poppet type (PVP) in solid Stellite™

## PISTONS

- Chrome coated stainless steel
- Tungsten carbide coated stainless steel
- Solid ceramic

## HOMOGENIZING VALVE

- Pneumatic actuated
- Wear parts made of tungsten carbide, ceramics as option
- High efficiency NanoVALVE™ as option

## PRESSURE GAUGE

- Sanitary design analog high pressure gauge

## PRODUCT LINE CONNECTIONS

- DIN 11851, Tri-Clamp™
- Others as option upon request

## POWER END

- Rugged cast iron power frame
- Forced lubrication with low oil pressure switch
- Polished SS machine casing on painted steel frame

## MAIN OPTIONS

- High pressure pump version
- 2nd stage homogenizing valve
- Electric power board for fixed or variable capacity

**COMPANY**  
**WITH QUALITY SYSTEM**  
**CERTIFIED BY DNV**  
**=ISO 9001/2000=**

GEA Niro Soavi S.p.A.

Via A. M. Da Erba Edoari, 29 - I - 43100 PARMA ITALY  
 Tel. +39 0521.965411 - Fax +39 0521.242819  
 www.niro-soavi.it