

Liquids to Value



TwinPanda 600

From the world leader
in high pressure
homogenization:
absolute quality
and reliability
with advanced
technical solutions
for any process need.

This small table-top unit, designed for continuous operation at high pressure, is the perfect equipment for laboratory scale high pressure processing of food, dairy and beverage, fruit juices, liquid food, food additives and ingredients.

COMPRESSION BLOCK

- High grade Super Duplex stainless steel
- Designed to ensure the maximum stress resistance to maximise the performances and reliability at high operating pressure
- Solid ceramic pumping plungers equipped with specially designed packings to avoid the need of lubrication water
- Suction and delivery ball valves (PVB) in Stellite™, with replaceable suction valve seat in Stellite™
- Transducer with integrated digital display and 4-20mA remote pressure signal

HOMOGENIZING VALVE

- Wear parts in tungsten carbide, fully reversible
- Manual pressure adjustment by means of a hand-wheel
- Second stage homogenizing valve as standard
- Allow front/side/upwards outlet to match with plant piping layout

PRODUCT INLET/OUTLET

- Tri-Clamp™ connections for inline installation
- No feeding pump is needed (for product viscosity up to 1000 cP)
- SS feeding hopper (2.5 l) supplied as standard

POWER END

- Maintenance - free timing belt drive
- Three phase motor, suitable for variable speed drive
- Camshaft drive system and maintenance-free grease lubrication

CASING

- Panels made in polished stainless steel, completely removable for maintenance and cleaning
- High quality paint steel base frame
- Adjustable anti-vibration rubber feet

CONTROL PANEL

Safety kit including:

- 1 plastic control board fixed inside the machine, 2 emergency pushbutton, Start/Stop pushbutton 3 Transducer with integrated digital display and 4-20mA remote pressure signal.
- The system stops machine when pressure is over 660 bar



TwinPanda 600

DIMENSIONAL DRAWING

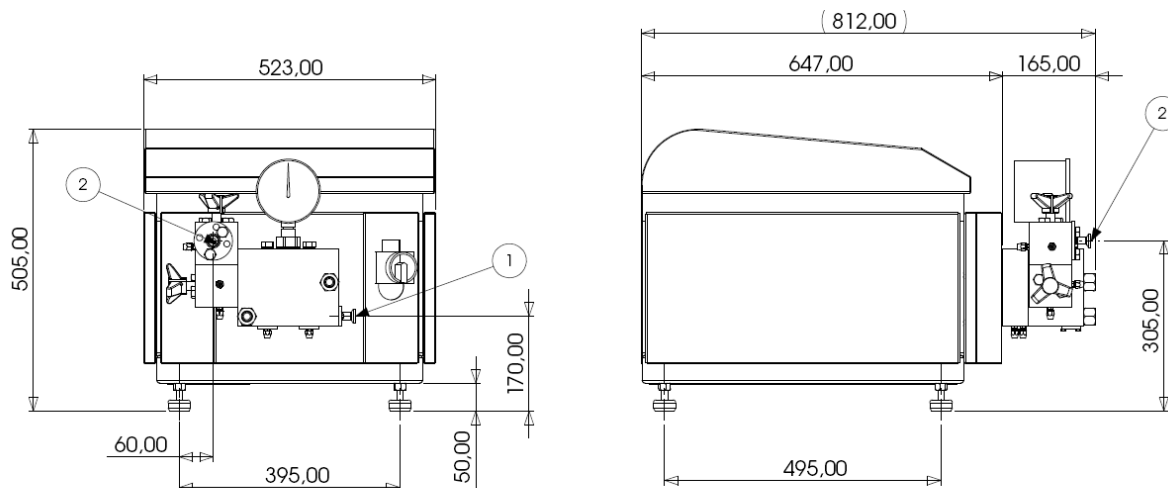

measure in mm

The TwinPANDA 600's flexibility makes it a useful tool for many different sectors. Tests can be run even with small sample volumes, and the results are comparable with those achieved on bigger size machines. The machine is suitable for CIP and SIP.

DESIGN FEATURES AND PERFORMANCES

Max operating pressure 600 bar

Flow rate of 30 l/h @ 600 bar

Minimum sample volume approx 500 ml

Three-phase motor 1.5 kW @ 400V / 50 Hz

Weight 143 Kg

Dimensions mm W 460 x H 420 x L 800

Connections in/out 1/2" Tri-Clamp™

Feeding hopper volume 2,5 l

AVAILABLE OPTION

- 3A version
- FDA approved gaskets
- Suitable for CIP/SIP
- Aseptic version
- Suitable for variable speed drive



GEA Mechanical Equipment

GEA Niro Soavi

Via A. M. Da Erba Edoari, 29 - I 43123 Parma (Italy)

Phone + 39 0521 965411 Fax +39 0521 242819

Info.GeaNiroSoavi@geagroup.com www.niro-soavi.com