

## Liquids to Value



### Panther NS3006L

From the world leader  
in high pressure  
homogenization:  
absolute quality  
and reliability  
with advanced  
technical solutions  
for any process need.

PantherNS3006L is a standalone fully equipped laboratory unit for food & beverage, pharmaceutical, biotechnology, cosmetic, chemical testing or small production, featuring the performances of the industrial scale homogenizers.

#### COMPRESSION BLOCK

- Constructed from Super Duplex SS alloy and fitted with wear resistant components to maximise the service life at high operating pressure
- Solid ceramic pumping plungers equipped with specially designed packing for very high pressure applications
- Suction and delivery ball valves (PVB) in special alloy, highly resistant to abrasion, with replaceable valve seats in Stellite™
- Sanitary design analog pressure gauge, with built-in pulsation damper
- Spring loaded overpressure relief valve
- Multiblock VHP construction

#### HOMOGENIZING VALVE

- Rupture type sharp-edge homogenizing valve (Stellite™) in special abrasion and wear resistant material
- Manual pressure adjustment by means of a hand-wheel
- Second homogenizing stage included with flat profile homogenizing valve
- A range of different homogenizing valve geometries are available for both stages. Re+VALVE available
- Wear parts made of tungsten carbide or ceramics

#### FEEDING SYSTEM

- Stainless steel feed funnel (5 l capacity) with connecting pipework to the feeding pump (inclusive of 10 Mesh filter and Tri-clamp fittings)

- Lobe type pump driven by a separate electric motor with built in variable speed drive unit to adjust the feed pressure according to the product viscosity. All product contact parts are in AISI 316
- By-pass valve for re-circulating the product into the funnel and pressure gauge to read the inlet pressure

#### POWER END

- Toothed belt drive
- Three phase motor
- Crank drive with splash lubrication

#### CASING

- Made in polished stainless steel, completely removable for maintenance and cleaning, with galvanized steel base frame
- The machine is mounted on castors for easy handling

#### CONTROL PANEL

- Electric Power Board in plastic box (IP55 protection) located inside the machine casing. Assembled according to CE standards
- Start/Stop push buttons for homogenizer and feed pump, emergency stop and pump speed adjustment are located on the front panel of the machine



# Panter NS3006L

## DIMENSIONAL DRAWING

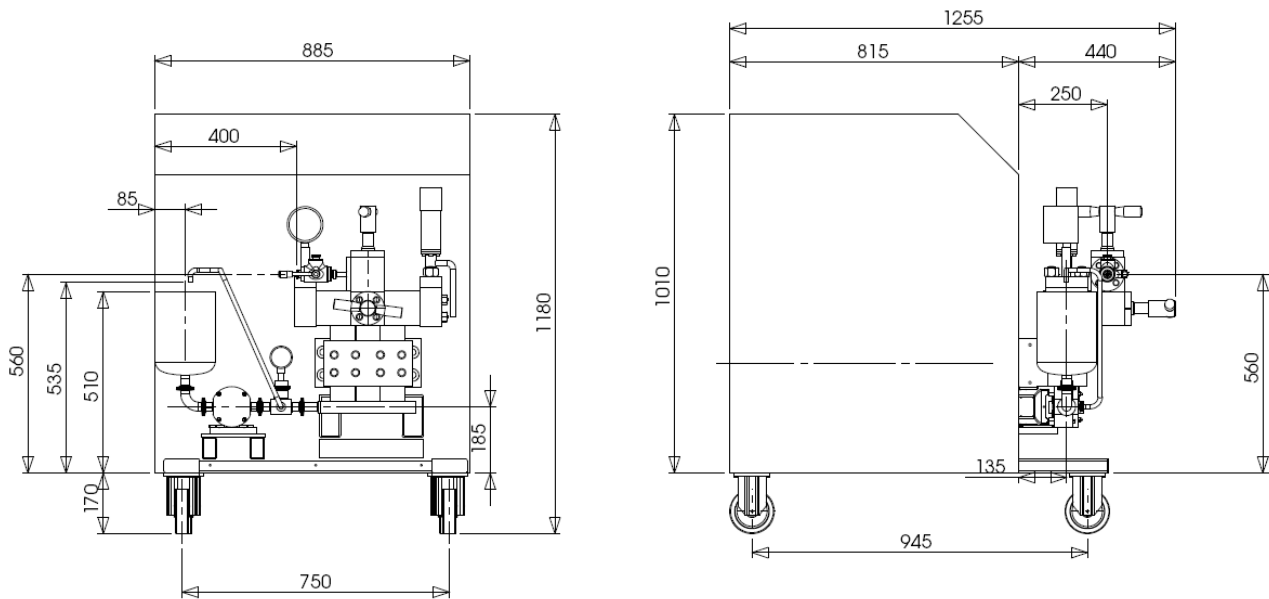

measure in mm

This pilot high pressure homogenizer unit is designed for continuous operation up to 1500 bar and for limited productions. The machine achieves the same results as bigger size homogenizers, and its compact design allows at the same time easy installation, simple operation and quick maintenance. Suitable also for viscous products, it can be used in many different sectors, such as food, dairy, chemical, pharmaceutical, cosmetics and biotech.

## PERFORMANCES

Pressure (bar)	Max Flow Rate (l/h)
150	-
180	-
200	-
250	-
400	-
600	-
1000	120
1200	100
1500	50

## TECHNICAL DATA

Number of plungers	3
Stroke	40 mm
Motor power	5,5 kW
Weight	600 kg
Lubricating and cooling water	60 l/h
Lubricating oil ISO VG 150	3 l
Feeding hopper volume	4,5 l

## COMPRESSION HEAD

- Multiblock VHP construction

## PUMP VALVES

- Ball type (PVB in Stellite™)

## PRODUCT LINE CONNECTIONS

- Tri-Clamp™

## POWER END

- Cast iron power frame
- Splash lubrication
- Polished SS machine casing on galvanized steel frame

## AVAILABLE OPTIONS

- Suitable for pharma applications
- Electropolished version (Ra 0,5 µm) available as option
- 3A execution, FDA approved gaskets, cGMP validation documentation available upon request
- Suitable for CIP/SIP
- Aseptic execution

Technical specifications are not mandatory and subject to change without notice. REV.1\_/2012



GEA Mechanical Equipment

**GEA Niro Soavi**

Via A. M. Da Erba Edoari, 29 - I 43123 Parma (Italy)

Phone + 39 0521 965411 Fax +39 0521 242819

Info.GeaNiroSoavi@geagroup.com www.niro-soavi.com